

CANDY PROCESS EQUIPMENT

LOYNDS CUT & PILLOW PACK MACHINE

FOR THE CUTTING & WRAPPING OF SOFT, HARD CANDIES & GUM IN A PILLOW PACK STYLE WRAP

The Cut & Pillow Pack Machine operates at speeds of up to 350 packs per minute and is complete with a print registration unit. It is suitable for soft candy & gum.

The unit consists of a double infeed roller section, cutting, piece transfer, transport chain, wrapping & section.

The machine is used with a batch roller & rope sizer or in some cases with an extruder to give a complete automatic candy forming line.

The machine can be manufactured to form & wrap either small pieces or longer bars.

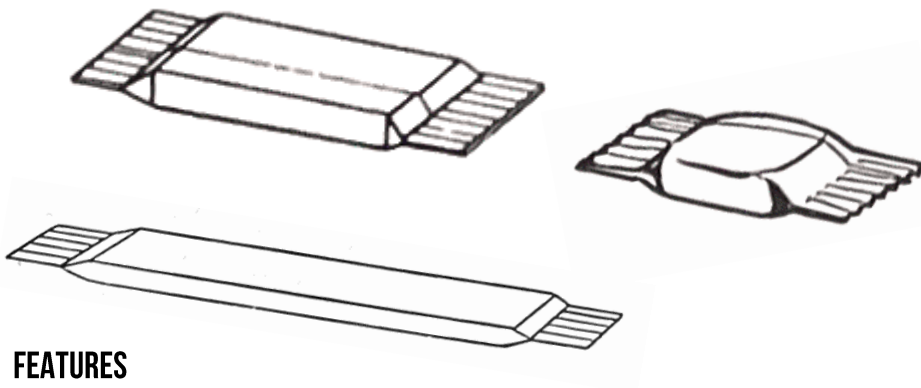

FEATURES

- Rectangle, square or cylindrical packaging shape
- Packaging length up to 160mm
- Packaging width up to 20mm
- Packaging height up to 18mm
- Dual film reel holder
- Print registration unit

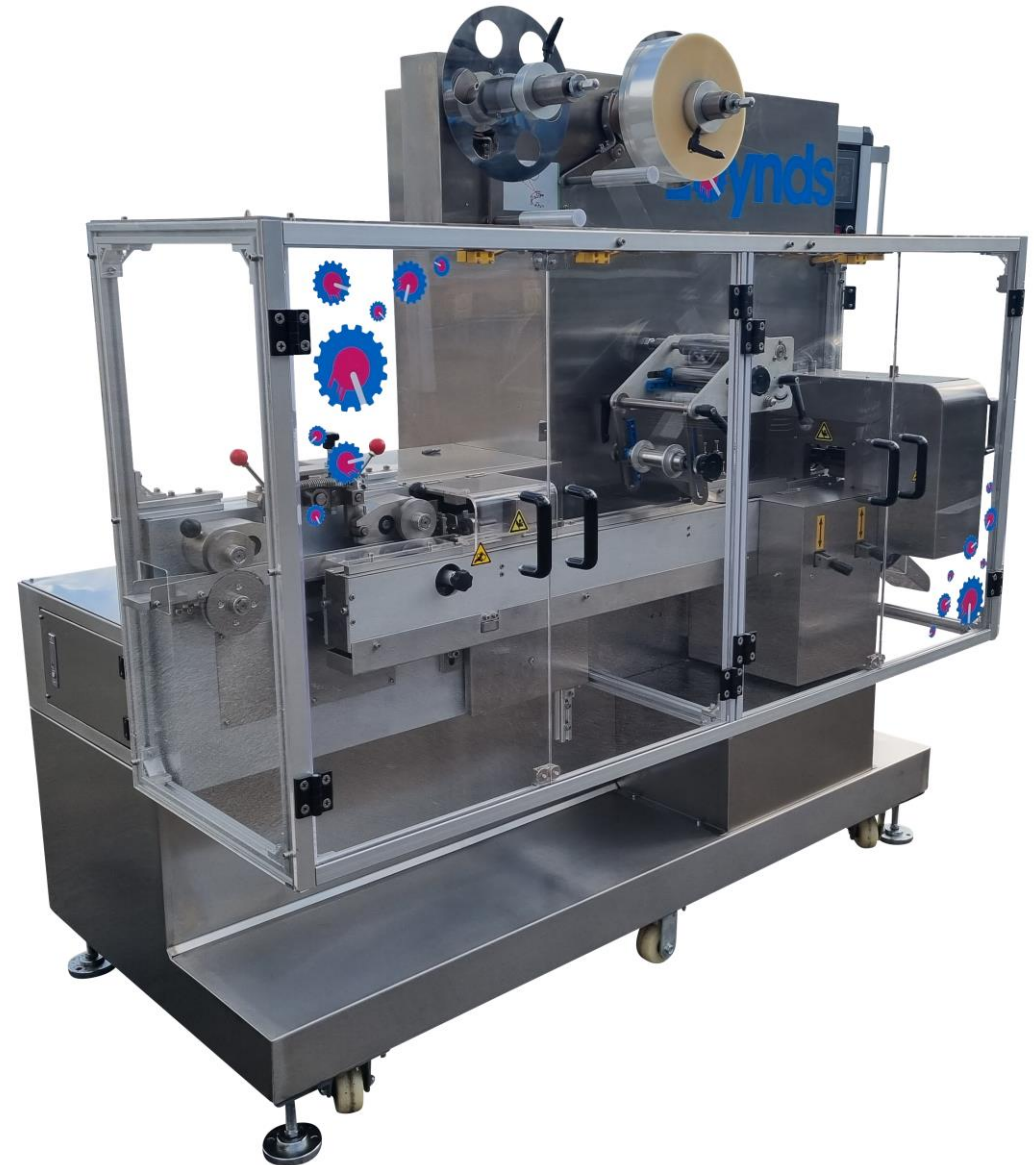

LOYNDS CUT & PILLOW PACK MACHINE

SPECIFICATIONS

Overall Height
1550mm

Overall Length
2250mm

Overall Width
900mm

Material
Machine - 304 Stainless Steel outer panels.

Output
Up to 350 wraps per minute depending on sweet size

Weight
Machine = 1250Kg

Products
Soft Candies and gum

