

BAGGING EQUIPMENT

BUCKET ELEVATOR

FOR CONVEYING PRODUCT UPWARDS, TOWARD A VERTICAL BAGGING MACHINE SETUP

Loynds' Bucket Elevator is as the vertical equipment for conveying those scattered materials, widely used in the food industry.

When equipped with other relative components, the Bucket Elevator finishes the whole process from loading the materials at the bottom and through the chain buckets conveying to discharging at the top.

FEATURES

- Suitable for all kinds of foodstuffs
- Vibratory hopper loads each bucket until full
- Safe transport of product up to weigher
- Vertical lifting, 90 degree transportation saves floor area and reduces power cost
- Chute to carry the materials to avoid scattering
- filling while follows up with packing machine and multi-steelyard.
- Transport quality : 4000 (liters/hour) 7200 (liters/hour)
- Lifting height : made to your requirements



BUCKET ELEVATOR SPECIFICATIONS

Material

Stainless Steel

Length

To customer's requirement

Height

To customer's requirement

Width

To customer's requirement

Output

4000-7200 liters per hour

Weight

600kg

Power

0.75kw

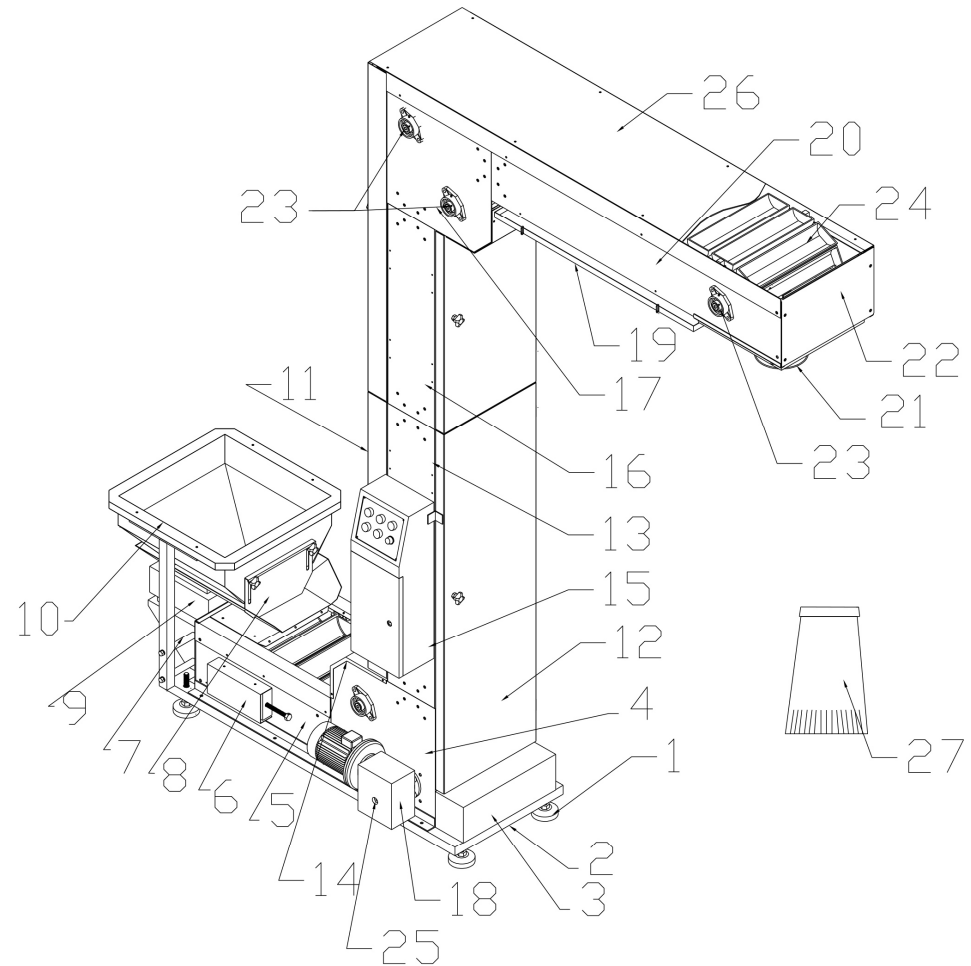

- | | | | |
|----------------------|---------------------|-----------------------|---------------------------|
| 1 Adjustable foot | 6 Fixed Seat | 7 Seat for vibrator | 8 Down corner part |
| 5 Down tail part | 10 Feed hopper | 11 Front door board | 12 Back door board |
| 9 Vibrator & Hopper | 13 Down-middle part | 14 Down cover board | 15 Electrical Control box |
| 17 Upper corner part | 18 Motor Retarder | 19 Tray (selected) | 16 Upper-middle part |
| 20 Upper part | 21 Discharge hopper | 22 Upper part panel | 23 Passive spindle |
| 24 Chain Bucket | 25 Active spindle | 26 Convey chain wheel | |
| 27 Discharge hopper. | | | |