

MINI CANDY DEPOSITOR

COMPACT DEPOSITING MACHINE, IDEAL FOR USE BY THE SMALLER MANUFACTURER OR IN THE LABORATORY. FOR JELLIES, GUMMIES, HARD CANDIES, CARAMELS & LOLLIPOPS. IDEAL FOR CBD, THC & VITAMIN INFUSED PRODUCTS.

The machine is servo motor controlled via a PLC & HDMI touch screen. Deposits and settings can be easily controlled and stored.

Put the mould in position and push the two buttons and one mould will be indexed and deposits are automatically made to fill the mould, this is then repeated.

Moulds then leave the depositor, and the moulds can be cooled as the user prefers. Or the option of extension rails can be purchased so the moulds travel along rails giving a more flowable production system. A further option of overhead fans that can be mounted over the rails, that blow down directly onto the moulds.

FEATURES

- Touch screen control on swivel arm
- Mounted on lockable wheels with anchor feet
- Easy to use
- Easy use, clean & to maintain
- Hopper Configurations for two colours drops

OPTIONS

- Moulds: Silicone, Teflon Coated and 3D Lollipop Moulds
- Hoppers: single or double colour.
- Hopper for stripes.
- Hopper for two colour products, one colour on top of each other.
- Custom moulds.
- Outlet rails.
- Depositing hopper auto fill unit (not suitable for all products)



MINI CANDY DEPOSITOR

SPECIFICATIONS

Overall Height
1600mm

Overall Length
1050mm

Overall Width
1150mm

Material
Machine Outer - 304 Stainless-Steel

Power
4kW Single phase

Weight
450Kg

Output
Up to 120kg per/hour depending on product.

Products
Jellies, Gummies, Hard Candies,
Caramels and Lollipops.

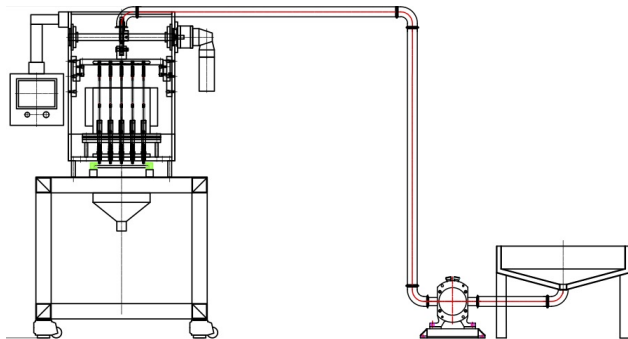

Automatic hopper fill unit

